

Feed module

Operating instructions
spare parts list

1 Introduction

1.1 Description

This operating manual explains how to connect and work with the feed module for power packe BE-S / BE-S2.

1.2 Third-party aggregates

If other power packes than HYDROSTRESS are used, they must comply with the following technical data:

delivery rate	max. 60 l/min
operating pressure	max. 240 bar

1.3 Qualification of operating personnel

Machining concrete and stone is neither simple nor without danger. High material assets on the job site, the machine itself and the safety of people are at stake.

The personnel has to be trained by experienced experts.

1.4 The exclusive use of genuine HYDROSTRESS spare parts ensures quality and interchangeability.

In the case of neglected or inappropriate maintenance, we refuse to accept any warranty commitment as specified in our terms of delivery.

Any repair work is to be carried out by trained personnel only.

Should you need to know more details concerning your HYDROSTRESS system in order to keep it in perfect condition, please contact our after-sales service for further information.

We would be pleased to hear that working with your HYDROSTRESS system was without any difficulties and troublefree.

HYDROSTRESS AG
The Management

Copyright © HYDROSTRESS AG, 1999

HYDROSTRESS AG Witzbergstrasse 18 CH-8330 Pfäffikon Switzerland Telefon 0041 (0)44 952 18 18 Telefax 0041 (0)44 952 18 00
--

2 Table of contents

1	Introduction	2
1.1	Description	2
1.2	Third-party aggregates	2
1.3	Qualification of operating personnel	2
1.4	The exclusive use of genuine HYDROSTRESS spare parts ensures quality and interchangeability.	2
2	Table of contents	2
3	How the feed module operates	3
3.1	Description	3
3.2	Hydraulic data with BE-S aggregate	3
3.3	Hydraulic data with BE-S2 aggregate	3
4	Setup procedure	4
4.1	Connecting hydraulic oil hoses	4
4.2	Prior to operation	4
5	Operation	5
5.1	Switch on the power packe	5
5.2	Shutdown procedure	5

3 How the feed module operates

3.1 Description

The feed module divides the hydraulic flow of the BE-S / BE-S2 power pack into a main circuit and a feed circuit.

This enables e.g. a drilling machine to be operated with **hydraulic** feed, even with a single circuit aggregate.

3.2 Hydraulic data with BE-S aggregate

Aggregate without feed module	33 l/min at 130 bar
Aggregate with feed module	30 l/min at 130 bar
Feed rate	3 l/min at 110 bar

3.3 Hydraulic data with BE-S2 aggregate

Aggregate without feed module	33 l/min at 170 bar
Aggregate with feed module	30 l/min at 170 bar
Feed rate	3 l/min at 110 bar

4 Setup procedure

4.1 Connecting hydraulic oil hoses

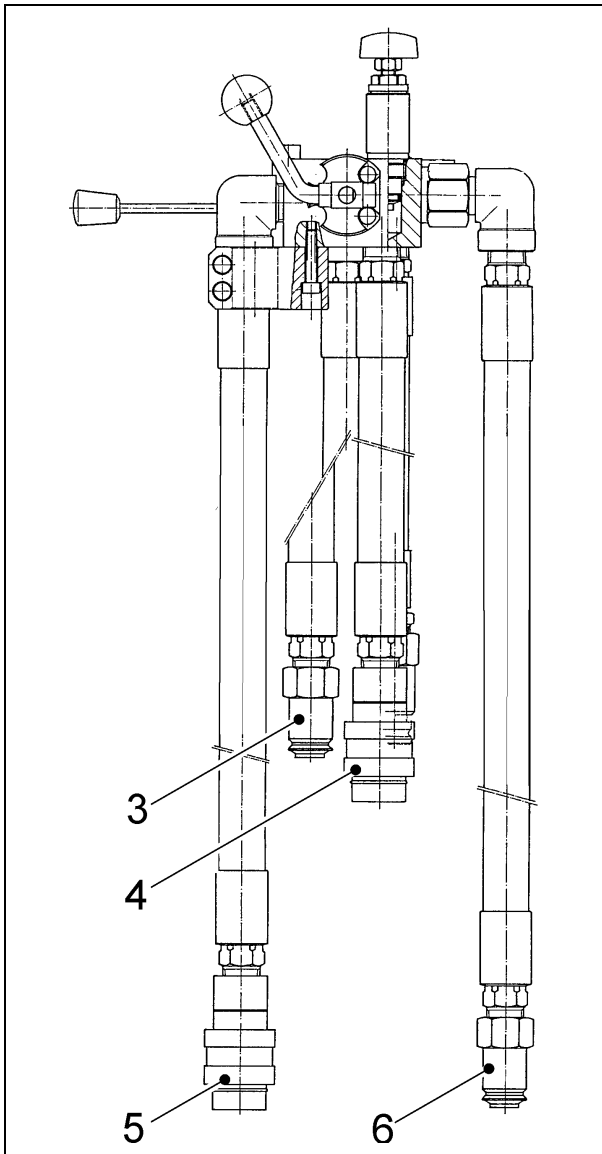

Fig. zus-stn4.tif

- Connect the long main circuit hoses (5,6) of the feed module to the **power pack**
- Connect the short main circuit hoses (3,4) of the feed module to the main circuit hoses on the **driven machine**
- Connect the feed circuit hoses (1,2) of the feed module to the **feed hoses** on the driven machine

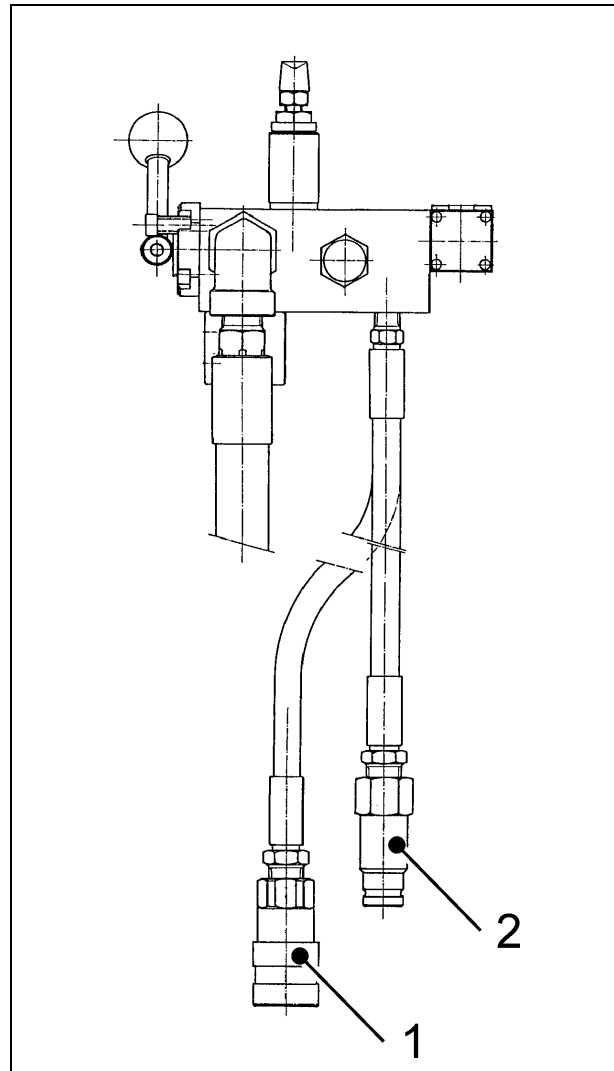

Fig. zus-stn3.tif

4.2 Prior to operation



The power pack must be at a safe distance from the machine to ensure personal protection in the event of tool damage.

- Cover all sharp rubbing edges to prevent hose damage
- Check that water is emitted at the tool

5 Operation

5.1 Switch on the power pack

The main valve (8), feed valve (7) and pressure control valve (9) must always be set at zero before starting the power pack.

- 1) Main valve (8) in zero position
- 2) Feed valve (7) in zero position
- 3) Pressure control valve (9) in zero position (completely unscrewed)
- 4) Open the water valve on the power pack
- 5) Switch on the aggregate

5.1.1 Switch on the main circuit pump

- 1) Set the main valve (8) in position 1. The driven machine now starts operating

The operating pressure varies according to machine load between less than 10 bar minimum (idling), and 130 bar (BE-S) or 170 bar (BE-S2) maximum.

Maximum pressure is limited by a relief valve to 130 bar (BE-S) or 170 bar (BE-S2).

5.1.2 Switch on the feed pump

- 1) Set the feed valve (7) at position I (top or bottom)
- 2) Set the pressure with the control valve (9)
Clockwise: Increase pressure
Anticlockwise: Reduce pressure



Now check for correct feed travel in each direction, and note the respective positions of the feed valve (7).

All further operations are carried out from the hydraulic controls (7, 8, 9).

Operation at excessive pressure for long periods (continuous flow through relief valve) overheats the oil and can cause machine damage.

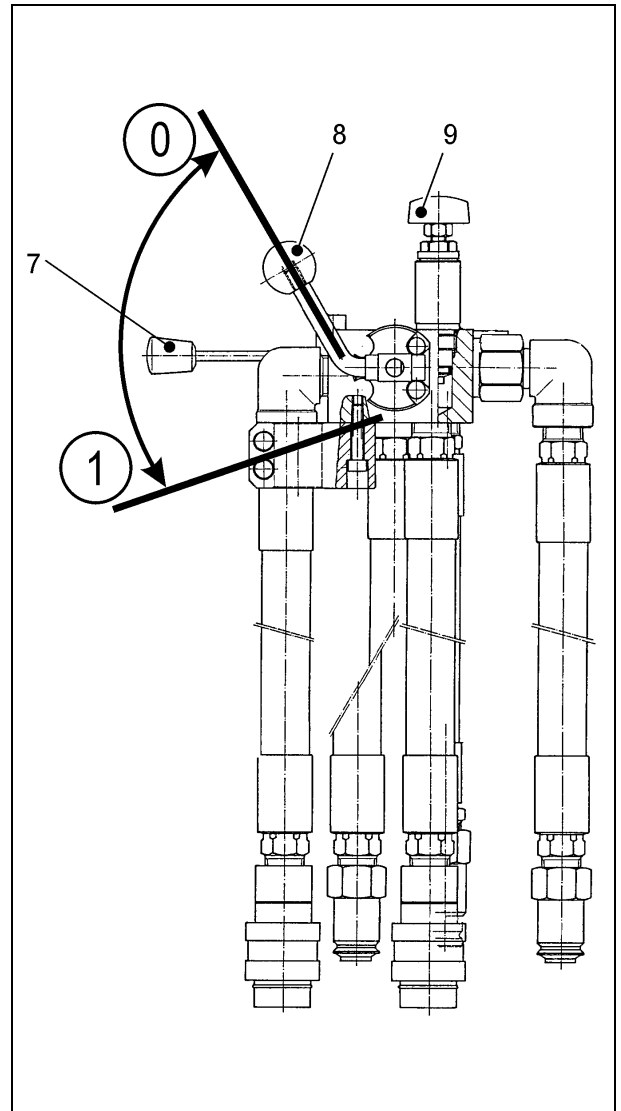

Fig. zus_stn1.tif

5.1.3 EMERGENCY STOP

To immediately halt all machine motions, press the emergency stop button on the **power pack**.

5.2 Shutdown procedure

- 1) Set the main valve (8) to position 0
- 2) Set the feed valve (7) to position 0
- 3) Set the pressure control valve (9) to position 0
- 4) Shut off the main power switch on the power pack
- 5) Close the water valve
- 6) Disconnect the hoses
- 7) Clean the power pack and hoses with water.

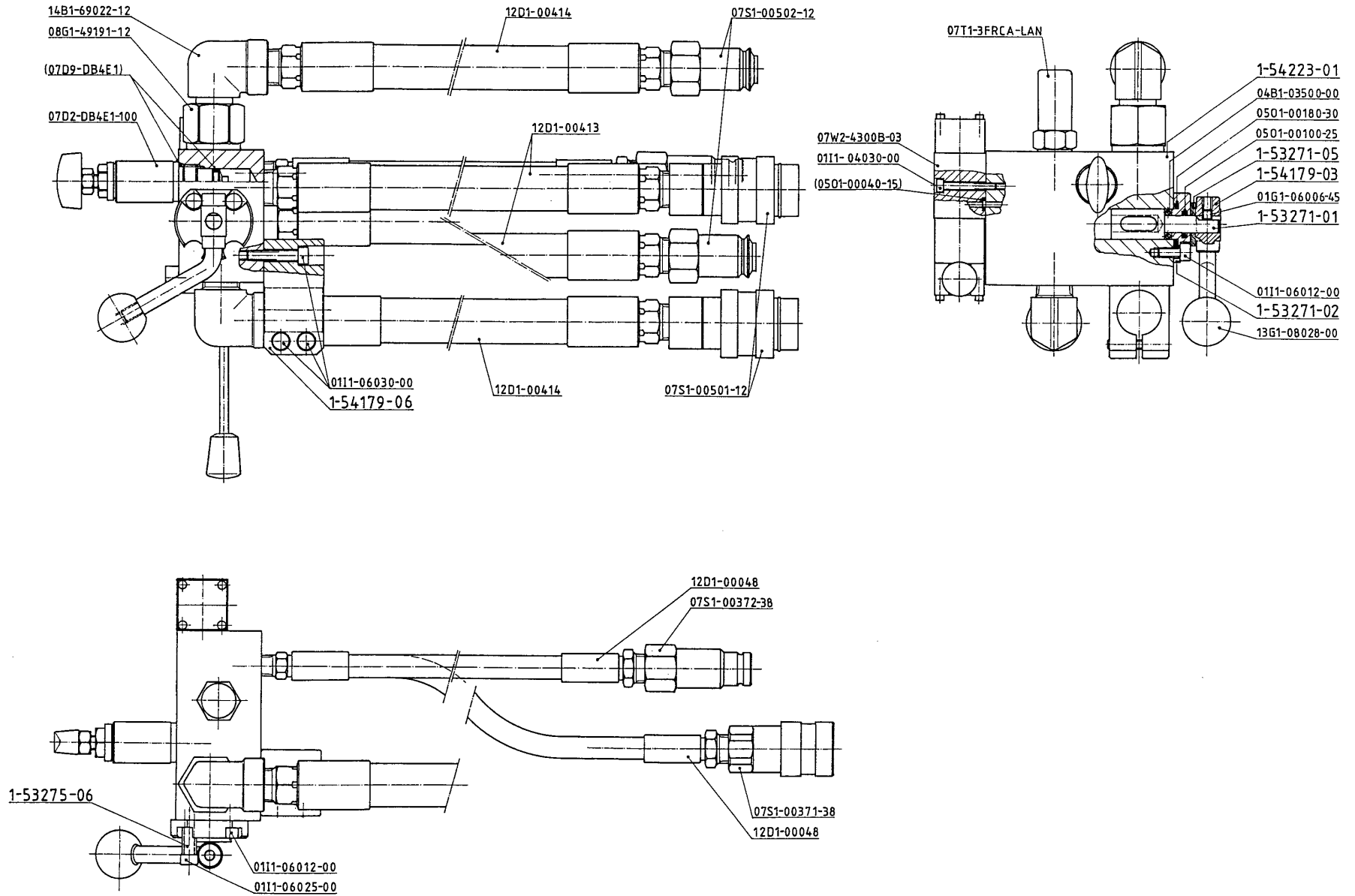

Fig. zus_stlg.tif

	Vorschubmodul BE-S	Kit d'avance BE-S	Valve kit assembly BE-S	
0001-53271-01	Drehhebel	Vanne de réglage GA, MM	Rotary valve GA, MM	1
0001-53271-02	Schieberdeckel	Couvercle du tiroir	Slide valve cover	1
0001-53275-06	Distanzhülse	Tube d'écartement	Spacer tube	1
0001-54179-03	Ventilhebel	Poignée	Lever to valve	1
0001-54179-06	Halter zu Vorschubmodul	Support	support	1
0001-54223-01	Sammelblock	Bloc collecteur	Collector block	1
01G1-06006-45	Gewindestift	Goujon M6 x 6	Set screw M6 x 6	1
0111-04030-00	Inbus-Schraub	Vis à six pans creux	Allen head screw	3
0111-06012-00	Inbus-Schraube	Vis à six pans creux	Allen head screw	2
0111-06020-00	Zylinderschraube M6 x 20	Vis à six pans tête	Allen head screw	1
0111-06030-00	Inbusschraube	Vis à six pans creux	Allen head screw	4
02S1-01010-50	Seegering Welle 10	Anneau Seeger (arbre 10)	Circlip for shaft 10	1
03T1-02310-09	Tellerfeder	Rondelle à ressort	Disk spring	2
04B1-03500-00	Kugel	Bille Ø 3,5 mm	Ball Ø 3,5 mm	12
05O1-00100-25	O-RING 10X2,5	Anneau O-Ring"10x2	O ring 10x2,5 N 70	1
05O1-00180-30	O-RING 18X3	Anneau O-Ring" 18x3 N 70"	O-ring seal	1
07D2-DB4E1-100	Druckregelpatrone DB4E1.1	Régulateur de pression	Pressure control	1
07D9-00DBV-90	Kappe zu DBV SUN	Couvercle limiteur de pr.	Cover for DBV Sun	1
07S1-00371-38	Kupplung 3/8 Zoll	Raccord 3/8 femelle	Coupling 3/8 female	1
07S1-00372-38	Nippel 3/8 Zoll	Raccord 3/8 mâle	Nipple 3/9 male	1
07S1-00801-12	Kupplung FD Mut.1/2 Zoll	Raccord femelle FD 1/2"	Coupling	2
07S1-00802-12	Nippel FD Vat. 1/2 Zoll	Raccord mâle FD 1/2"	Nipple	2
07T1-3FRCA-LAN	Mengenteilventil	Soupape de distribution	Distribution valve	1
07W2-4300A-03	Steuerschieber Nw3 A	Mannette de distribution	Spool valve A NW 3	1
08G1-49191-12	Gew.red. G3/4 A-G1/2 l	Réduction 3/4 E - 1/2 l	Fitting G3/4male-G1/2fem.	1
12D1-00048	Schlauch Nr. 048	Tuyau	Hose no. 048	2
12D1-00413	Schlauch Nr. 413	Tuyau	Hose no. 413	2
12D1-00414	Schlauch Nr. 414	Tuyau	Hose no. 414	2
13G1-08028-00	Kugelknopf	Boule pour poignée AZ	Ball-Grip M 8/Dm28	1
14B1-69022-12	Bogenstück 25 UG 08 1/2	Pièce coudée UG 08 ", "	Elbow piece	2